



1672 Donlon Street  
Ventura, CA 93003  
Local 805 654-6977  
Fax 805 654-6979  
www.jdcivil.com

VPD01.4558  
Thursday, March 28, 2024

To Whom it May Concern,

Attention to bidders of Ventura Harbor Public Boat Wash Station Replacement Project 1400 Anchors Way Dr., Ventura, California. Note, this is the fifth addendum for the rebid.

**Addendum No.5: Additional Project Information**

Additional Project Information:

- The Splash-N-Dash machines will be supplied by the Ventura Port District through a local vendor, and will be installed and commissioned under separate contract by the vendor.
- Local vendor for Splash-N-Dash must be included in the pre-construction meeting. The local vendor will be coordinated by the Ventura Port District.
- Bids for trenching conduit must be bid as open trenching along the path indicated.

Thank you for attending the pre-bid meeting and acknowledging this addendum. Remember to acknowledge all other addendums. We look forward to your bids.

James C. McCoskey, P.E.  
Senior Civil Engineer  
Jensen Design & Survey, Inc.

K:\VPD14558\Construction Management\2023 Boat Wash\Addendums\4558 Boat Wash Rebid Addendum No 5.doc



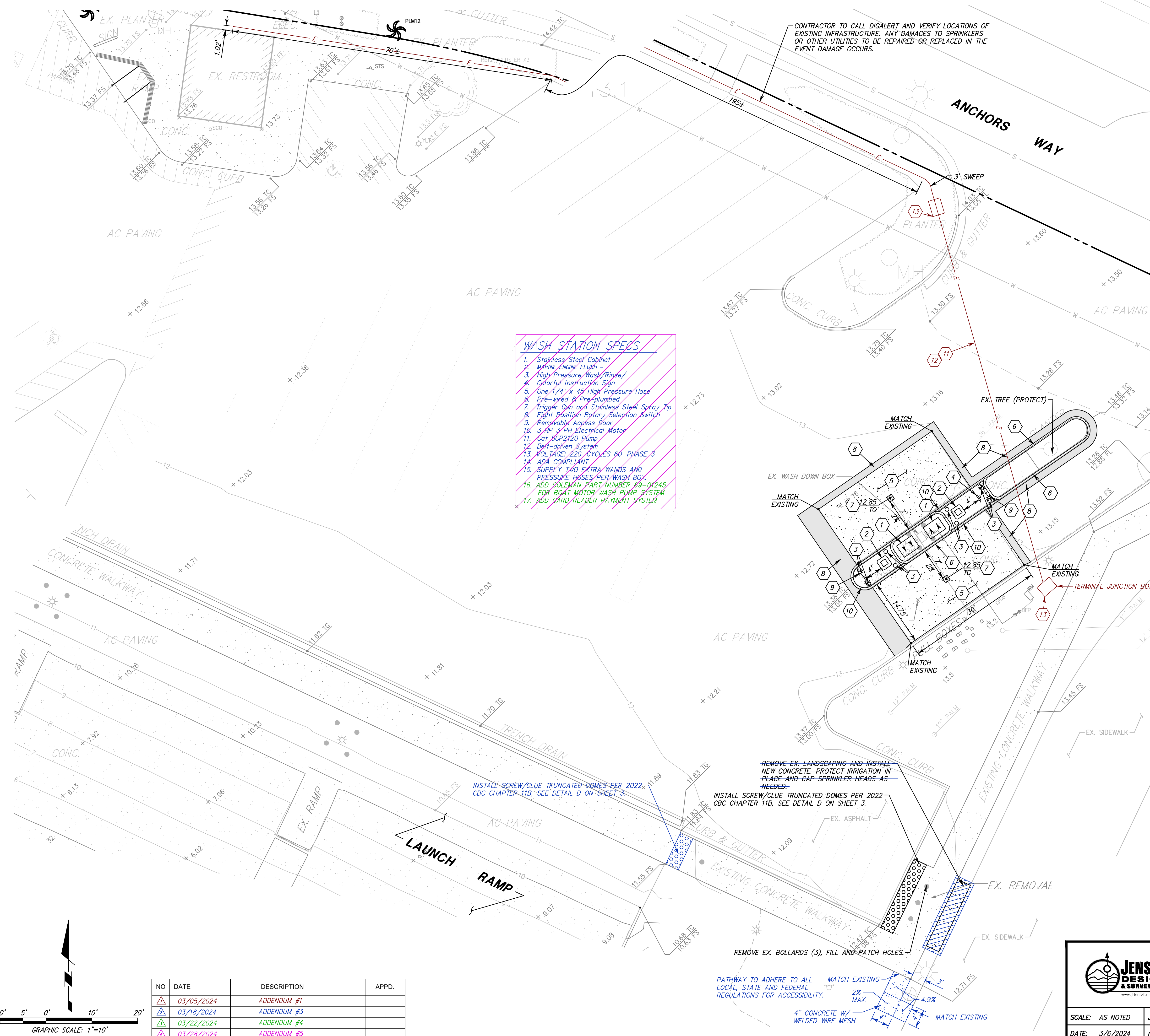

- WASH STATION SPECS**
1. Stainless Steel Cabinet
  2. Marine Engine Flush
  3. High Pressure Wash/Rinse/
  4. Colorful Instruction Sign
  5. One 1/4" x 45' High Pressure Hose
  6. Pre-wired & Pre-plumbed
  7. Trigger Gun and Stainless Steel Spray Tip
  8. Eight Position Rotary Selection Switch
  9. Removable Access Door
  10. 3 HP 3 PH Electrical Motor
  11. Cat BCP2120 Pump
  12. Belt-driven System
  13. VOLTAGE: 220 CYCLES 60 PHASE 3
  14. ADA COMPLIANT
  15. SUPPLY TWO EXTRA WANDS AND PRESSURE HOSES PER WASH BOX.
  16. ADD COLEMAN PART NUMBER B9-01245 FOR BOAT MOTOR WASH PUMP SYSTEM
  17. ADD CARD READER PAYMENT SYSTEM

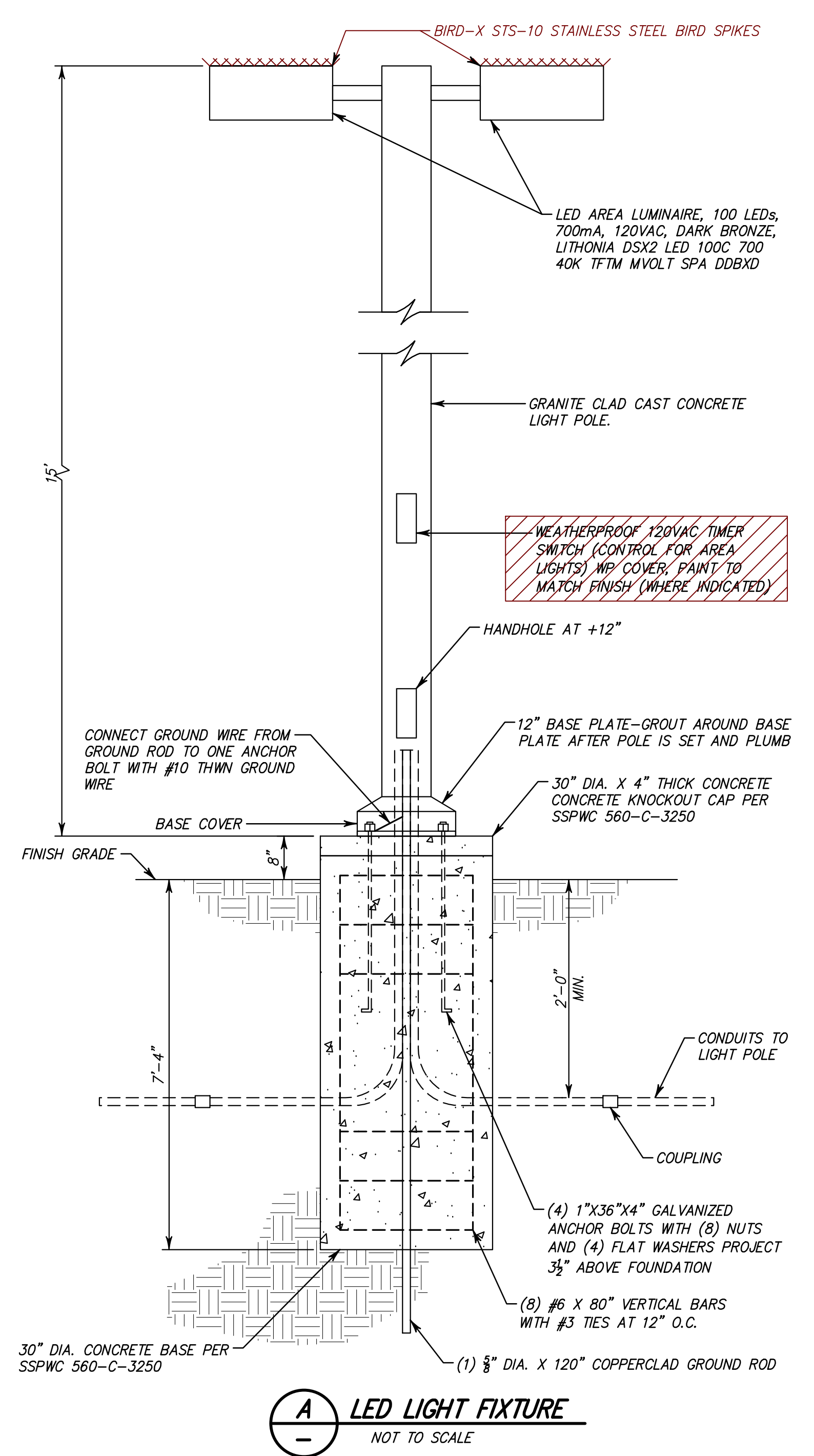

**CONSTRUCTION NOTES**

1. VENTURA PORT DISTRICT TO SUPPLY, INSTALL AND COMMISSION SPLASH-N-DASH MACHINES. LOCAL VENDOR MUST BE INCLUDED IN PRE-CON MEETING.
2. 53 GALLON SQUARE CONCRETE TRASH CAN WITH 12"x12" VENTURA PORT DISTRICT LOGO. LOGO PROVIDED BY DISTRICT.
3. INSTALL STAINLESS STEEL FIXED SECURITY BOLLARD PER DETAIL B, SHEET 3.
4. REINSTALL SALVAGED FISHING LINE RECYCLE CONTAINER AND SIGN.
5. 8" THICK 2,500 PSI CONCRETE WITH #4 BARS @ 13" O.C.E.W. OVER 8" CLASS II AGGREGATE BASE COMPACTED TO 95% RELATIVE DENSITY.
6. 6" CURB ONLY PER CITY OF VENTURA STD. PLATE 107, SEE DETAIL C ON SHEET 3.
7. 18"x18" CATCH BASIN WITH TRAFFIC RATED METAL GRATE WITH 2 SPARE GRATES PER CB. CALIFORNIA APPROVED FULL STAINLESS STEEL TRASH CAPTURE INSERT REQUIRED & INSTALL "DON'T DUMP DRAINS TO OCEAN" PLACARD. CONNECT TO EXISTING DRAIN PIPE(S).
8. PATCH BETWEEN SAWCUT AND NEW CONSTRUCTION WITH 8" (2 X 4" LIFTS) A.C. OVER 8" CLASS II AGGREGATE BASE COMPACTED TO 95% RELATIVE DENSITY.
9. INSTALL DOUBLE HEAD LIGHT POLE PER DETAIL A THIS SHEET.
10. 0" CURB PER CITY OF VENTURA STD. PLATE 107, SEE DETAIL C ON SHEET 3.
11. INSTALL 1.5" ELECTRICAL CONDUIT WITH #8 GAUGE STRANDED WIRE FROM JUNCTION BOX TO SOUTH CLARIFIER.
12. INSTALL A 1.25" EMPTY "COMMUNICATIONS" ELECTRICAL CONDUIT FROM RESTROOM JUNCTION BOX TO JUNCTION BOX AT SOUTH CLARIFIER AND 1" SPARE ELECTRICAL CONDUIT.
13. INSTALL 208V 3 PHASE CIRCUIT W/ TWO BLACK, RED, BLUE, AND WHITE NEUTRAL WIRES AS WELL AS ONE GREEN GROUND. ALL #8 GAUGE 9 WIRES TOTAL

NO	DATE	DESCRIPTION	APPD.
1	03/05/2024	ADDENDUM #1	
2	03/18/2024	ADDENDUM #3	
3	03/22/2024	ADDENDUM #4	
4	03/28/2024	ADDENDUM #5	

**JENSEN DESIGN & SURVEY, INC.**  
 1672 DONLON STREET  
 VENTURA, CALIF. 93003  
 PHONE 805/654-6977  
 FAX 805/654-6979  
 www.jdsd.com

SCALE: AS NOTED J.N.: VPD1.4558.019  
 DATE: 3/6/2024 DWG. NAME: 4558 BOAT WASH.dwg

**NEW BOAT WASH FOR VENTURA PORT DISTRICT**  
 1404 ANCHORS WAY  
 City of Ventura  
 COUNTY OF VENTURA STATE OF CALIFORNIA

**SHEET 2 OF 3**

